

Laurel Electronics Co., Ltd.

SPECIFICATION FOR TFT LCD MODULE

MODEL NO.: LT043C-50AT

(WITH TOUCH PANEL)

4.3", 480(RGB) x 272 TFT LCM WITH MCU INTERFACE

자세한 내용은 (주)가나시이스,
TEL: 02-2681-5611로 주시기 바랍니다.

REVISION	PREPARED	CHECKED	APPROVED
0.2	Y.D.Y.	L.Y.J.	L.Y.

RECORD OF REVISION

Date	Revision	Page	Revision Items
2012-08-28	0.1	-	New release
2014-09-23	0.2	5	Change serial font ROM from GT23L24T3Y to GT30L24T3Y.

자세한 내용은 (주)가나시이스,
TEL: 02-2681-5611로 주시기 바랍니다.

CONTENTS

1. General Description	4
2. Block Diagram	5
3. Interface Specifications	5
4. Absolute Maximum Ratings	7
5. Electrical Characteristics	7
6. Touch Screen Panel Specifications	13
7. Optical Specifications	14
8. Outline Dimensions	15
9. Precautions for Use of LCD Module	16

자세한 내용은 (주)가나시이스,
TEL: 02-2681-5611로 주시기 바랍니다.

1. General Description

Item	Specifications	Unit
LCD Type	Digital TFT	-
Display Color	256/65K	-
Active Area (WxH)	95.04 x 53.86	mm
Screen Size	4.3(Diagonal)	inch
Number of Dots	480(RGB) x 272	dot
Color Configuration	RGB-Stripe	-
Dot Pitch (WxH)	0.066 x 0.198	mm
Outline Dimension (WxHxT)	117.0 x 80.2 x 10.5	mm
Polarizer Mode	Transmissive	-
Viewing Direction	6:00	O'clock
LC		
Se	자세한 내용은 (주)가나시이스,	
Vc	TEL: 02-2681-5611로 주시기 바랍니다.	
Interface	8/16-bit 8080/6800 or 4-wire SPI	-
Backlight	White LED	-
Touch Panel	4-wire Resistive	-
Operating Temperature	-20 to +70	°C
Storage Temperature	-30 to +80	°C
Weight	100	g

Note: Please refer to RA8875 datasheet and GT30L24T3Y datasheet for details.

2. Block Diagram

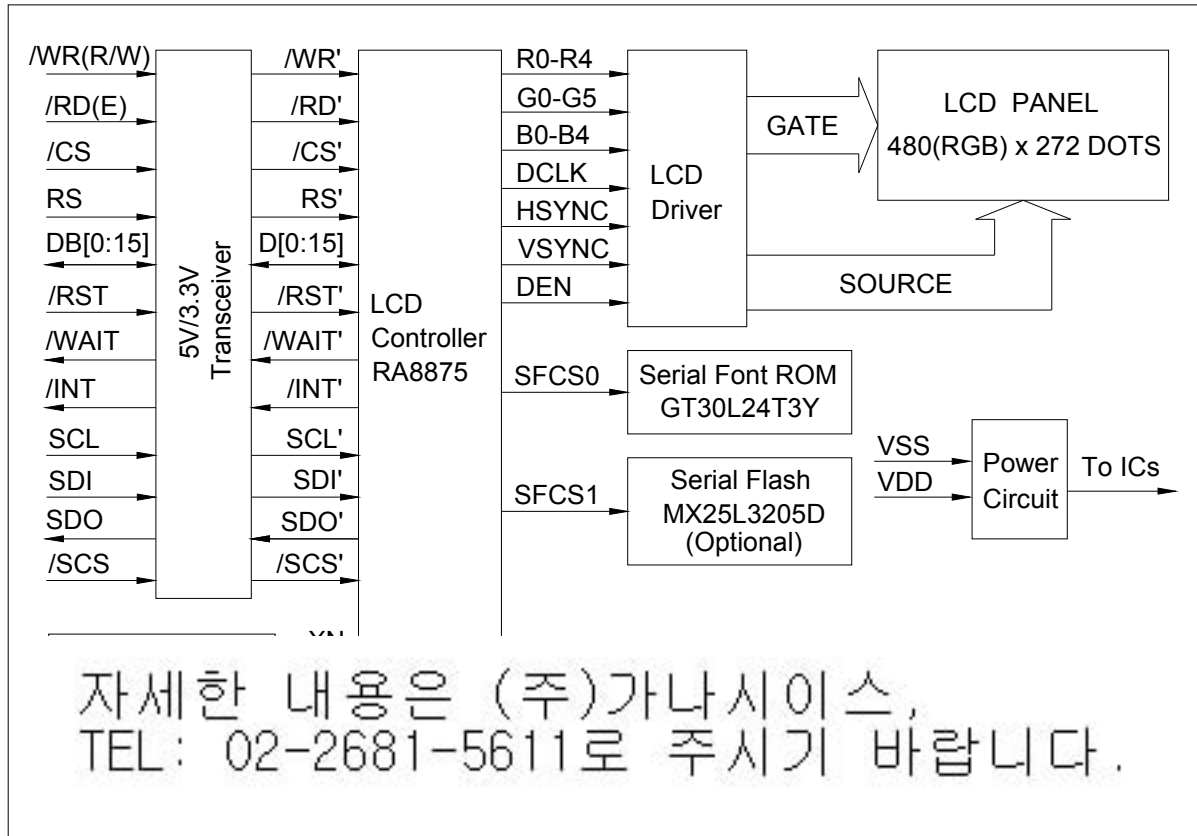

3. Interface Specifications

3.1 Set Bus Mode by on Board Jumpers

The interface bus mode is determined by the status of on board jumpers. The relationship between the status of jumpers and interface bus mode is below.

Jumper Status (C=Close; O=Open)										Interface Bus Mode
J2	J3	J4	J5	J6	J7	J8	J9	J10	J11	
O	C	O	C	C	O	O	C	O	C	8080 8/16-bit <Default>
O	C	C	O	O	C	O	C	O	C	6800 8/16-bit
C	O	O	C	C	O	O	C	C	O	4-wire SPI

Note: This lcn do not support 3-wire SPI or IIC mode.

3.2 Terminals Functions (CN1/CN2)

Pin No.	Symbol	Level	Function
1	VSS	0V	Ground (Connects to frame ground via jumper J1)
2	VDD	3.3V to 5V	Power supply for logic
3	VLED	3.3V to 5V	Power supply for LED backlight drivers.
4	RS	H/L	Data or command selection RS="H": Command; RS="L": Display data
5	/WR (/RW)	H/L	/WR(Write) signal for 8080 series MPU: Bus data is latched at the rising edge of /WR. R/W(Read/Write control) signal for 6800 series MPU: R/W="H": Read operation; R/W="L": Write operation.
6	/RD (E)	H/L	/RD (Read) signal for 8080 series MPU: Read bus data when /RD is "L". E (Enable) signal for 6800 series MPU: Read bus data when E is "H", write bus data at falling edge of E.
7	/CS	L	Chip selection signal. Active "L".
8	/RST	L	Reset signal. Active "L"
9	/WAIT	L	Wait signal output. Active "L". This is a /WAIT output to indicate RA8875 is in busv state. Keep /WAIT open when it is not used.

자세한 내용은 (주)가나시이스,
TEL: 02-2681-5611로 주시기 바랍니다.

to
ad.

Pin No.	Symbol	Level
12	DB1	H/L
13	DB2	H/L
14	DB3	H/L
15	DB4	H/L
16	DB5	H/L
17	DB6	H/L
18	DB7	H/L
19	DB8	H/L
20	DB9	H/L
21	DB10	H/L
22	DB11	H/L
23	DB12	H/L
24	DB13	H/L
25	DB14	H/L
26	DB15	H/L

Data bus.
For 8-bit data bus mode, keep DB8 to DB15 open.
(D8 to D15 inputs to RA8875 are pulled to HIGH by on board 100KΩ resistors).

3.3 Terminals Functions (CN3/CN4)

Pin No.	Symbol	Level	Function
1	VSS	0V	Ground (Connects to frame ground via jumper J1)
2	VDD	3.3V to 5V	Power supply for logic
3	VLED	3.3V to 5V	Power supply for LED backlight drivers.
4	SCL	H/L	SPI clock. Active at rising edge.
5	SDI	H/L	SPI data input.
6	SDO	H/L	SPI data output.
7	/SCS	L	SPI chip selection. Active "L".
8	/WAIT	L	Wait signal output. Active "L". This is a /WAIT output to indicate RA8875 is in busy state. Keep /WAIT open when it is not used.
9	/INT	L	Interrupt signal output. Active "L". The interrupt output for MCU to indicate the status of RA8875. Keep /INT open when it is not used.
10	/RST	L	Reset signal. Active "L"

Note: SCL, SDI, /SCS terminals are pulled to "H" by on board resistors.

4. Absolute Maximum Ratings

In 자세한 내용은 (주)가나시이스, In TEL: 02-2681-5611로 주시기 바랍니다.						
Input Voltage	VI	-	-0.3	VDD+0.3	V	

5. Electrical Characteristics

5.1 DC Characteristics (Ta=25°C)

Item	Symbol	Condition	Min	Typ	Max	Unit
Power Supply	VDD		3.3	5.0	5.5	V
Input High Voltage	VIH		2.0	-	VDD	V
Input Low Voltage	VIL		0	-	0.8	V
Output High Voltage	VOH	IOH=-0.1mA	VDD-0.2	-	VDD	V
Output Low Voltage	VOL	IOL= 0.1mA	0	-	0.2	V
Current Consumption (Logic)	IDD	VDD=5.0V	-	65	80	mA
		VDD=3.3V	-	60	75	mA
Current Consumption (LED B/L Drivers)	ILED	VLED=5.0V	-	80	100	mA
		VLED=3.3V	-	130	150	mA

5.2 LED Backlight Control

The LED backlight is driven by 1 pcs LED driver IC. The enable signal of LED drivers is connected with PWM1 of RA8875. The LED driver is turned on (when PWM1=1) or off (when PWM1=0) by PWM1 signal. The LED backlight operates at either zero or full current. The average LED backlight current increases proportionally with the duty cycle of the PWM1 signal. A 0% duty cycle will turn off the LED driver and corresponds to zero LED current. A 100% duty cycle corresponds to full current. The typical frequency range of the PWM1 signal can be 1 KHz or less.

(External Crystal=24MHz)

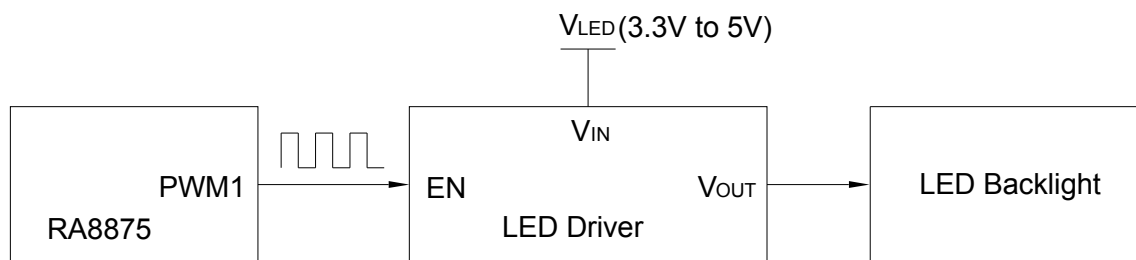

PWM1=1: LED B/L On
PWM1=0: LED B/L Off

V_{LED} : Power supply for LED drivers

자세한 내용은 (주)가나시이스,
TEL: 02-2681-5611로 주시기 바랍니다.

5.3 8080 8/16-bit Interface Read/Write Timing

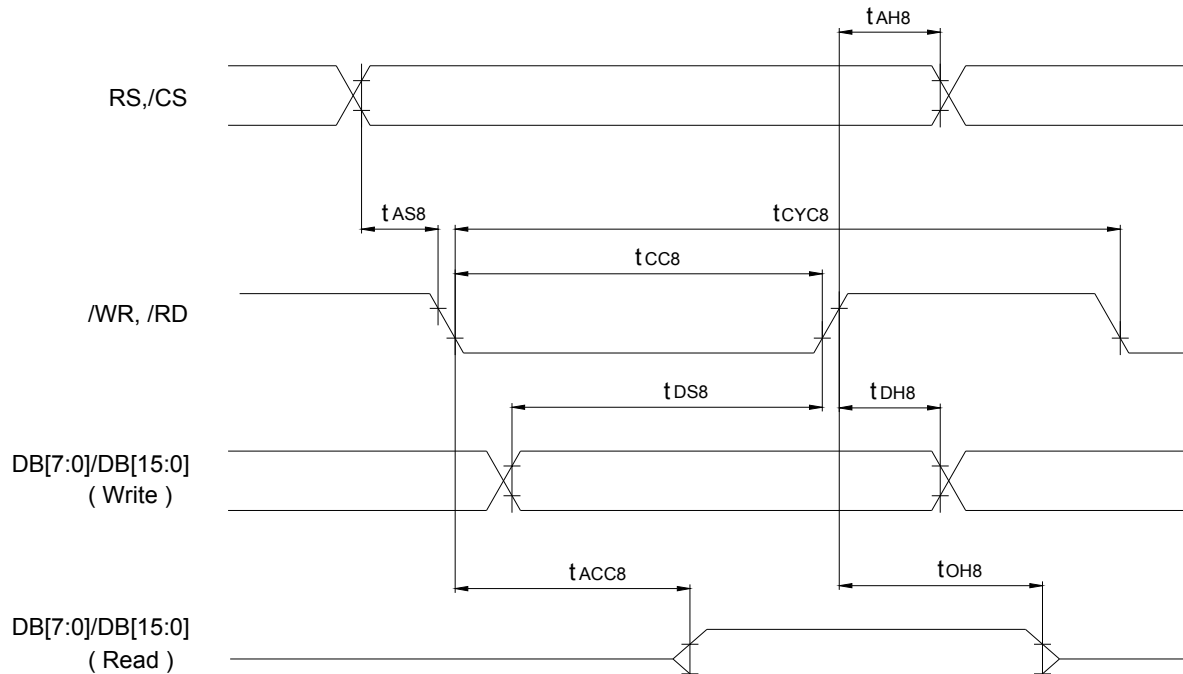

자세한 내용은 (주)가나시이스,
TEL: 02-2681-5611로 주시기 바랍니다.

(Ta=25°C)

Characteristic	Symbol	Min.	Max.	Unit
Cycle time	tCYC8	50	-	ns
Strobe Pulse width	tCC8	20	-	ns
Address setup time	tAS8	0	-	ns
Address hold time	tAH8	10	-	ns
Data setup time	tDS8	20	-	ns
Data hold time	tDH8	10	-	ns
Data output access time	tACC8	0	20	ns
Data output hold time	tOH8	0	20	ns

Notes:

1. tc=1/SYS_CLK
2. External Crystal=24MH

5.4 6800 8/16-bit Interface Read/Write Timing

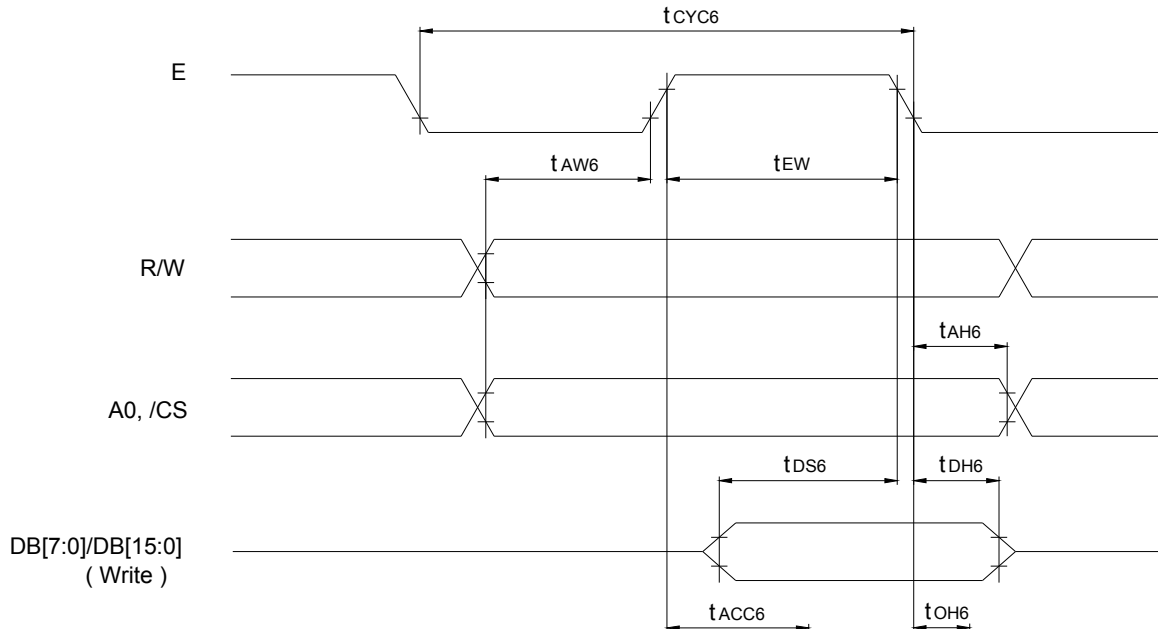

자세한 내용은 (주)가나시이스,
TEL: 02-2681-5611로 주시기 바랍니다.

For Read/Write Timing (0000 0000 0000 0000)

(Ta=25°C)

Characteristic	Symbol	Min.	Max.	Unit
Cycle time	t_{CYC6}	50	-	ns
Strobe Pulse width	t_{EW}	20	-	ns
Address setup time	t_{AW6}	0	-	ns
Address hold time	t_{AH6}	10	-	ns
Data setup time	t_{DS6}	20	-	ns
Data hold time	t_{DH6}	10	-	ns
Data output access time	t_{ACC6}	0	20	ns
Data output hold time	t_{OH6}	0	20	ns

Notes:

1. $t_c = 1 / \text{SYS_CLK}$
2. External Crystal=24MH

5.5 4-Wire SPI Timing Diagram

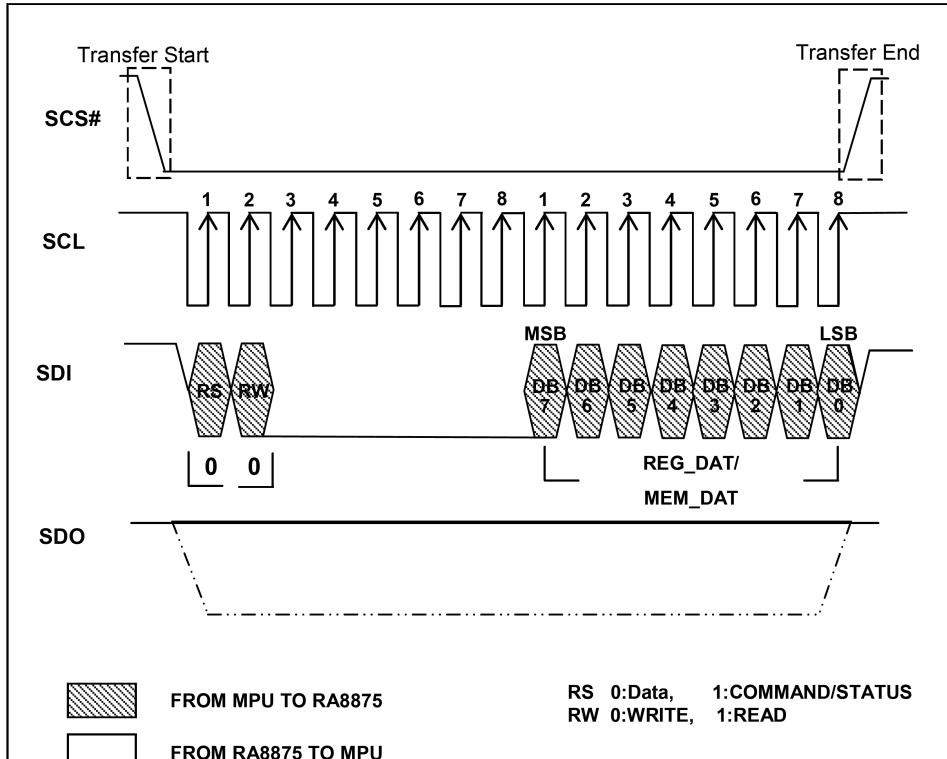

자세한 내용은 (주)가나시이스,
TEL: 02-2681-5611로 주시기 바랍니다.

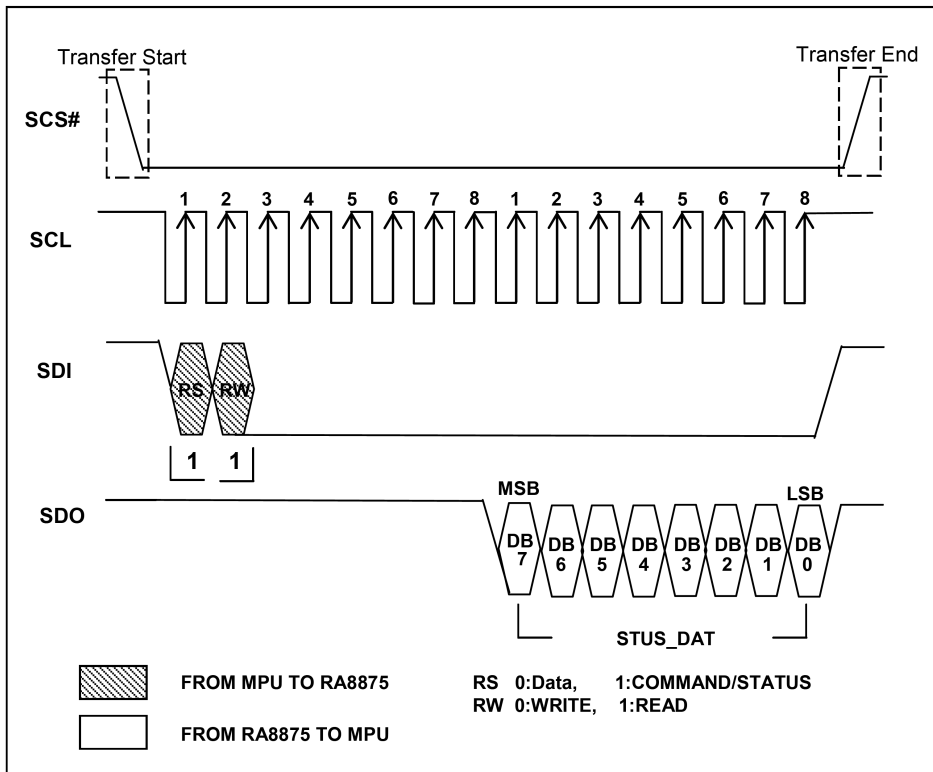

Data Read on 4-Wire SPI Bus

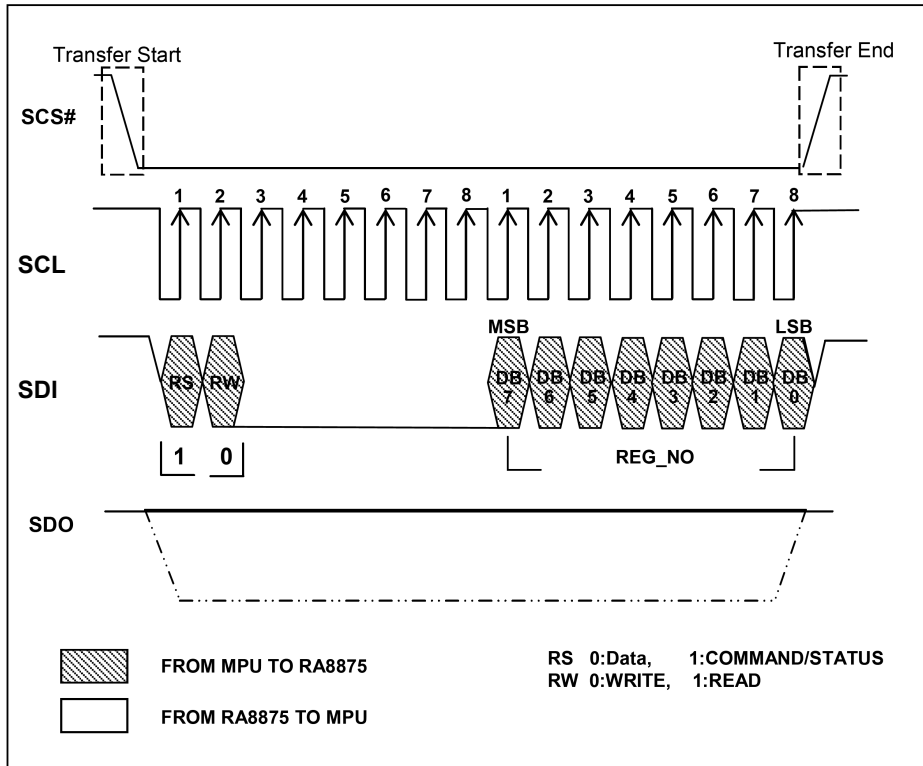

Command Write on 4-Wire SPI Bus

자세한 내용은 (주)가나시이스,
TEL: 02-2681-5611로 주시기 바랍니다.

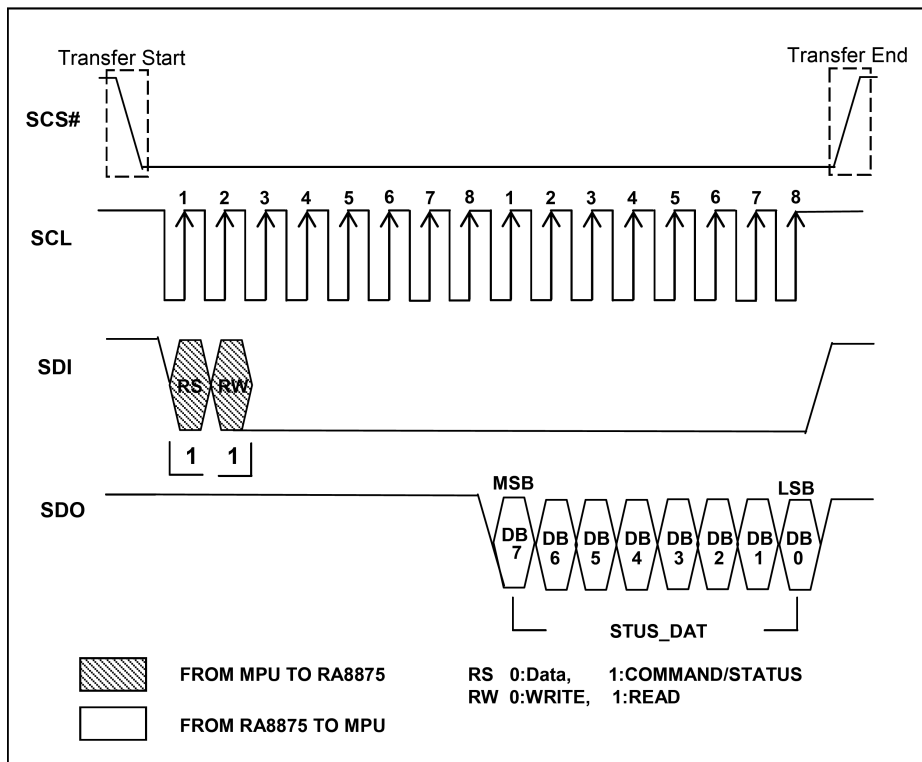

Status Read on 4-Wire SPI Bus

6. Touch Panel Characteristics

6.1 Electrical and Optical Characteristics (Ta=25°C)

Item	Min.	Typ.	Max.	Unit	Remark
Linearity	-1.5	-	1.5	%	X and Y directions
Circuit Resistance	260	-	1040	Ω	X direction
	160	-	640	Ω	Y direction
Insulation Resistance	10	-	-	MΩ	DC 25V
Operating Voltage	3.0	5	7	V	DC
Chatting Time	-	-	10	ms	
Transmittance	78	-	-	%	
Surface Treatment	Anti-glare				

6.2 Mechanical & Reliability Characteristics

자세한 내용은 (주)가나시이스, TEL: 02-2681-5611로 주시기 바랍니다.					
Knocking Durability	1,000,000	-	-	times	
Writing Durability	100,000	-	-	words	

6.3 Touch Panel Circuit Diagram

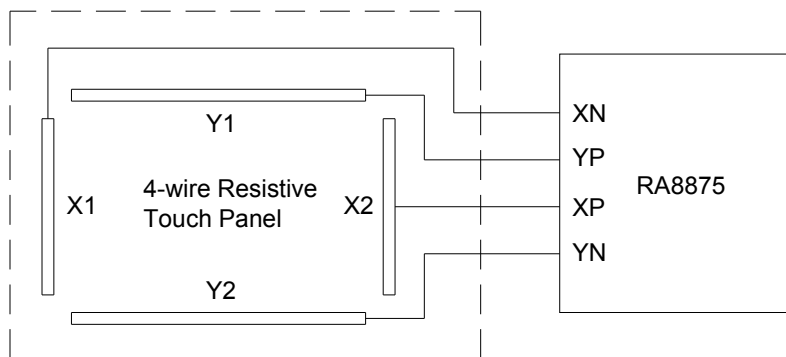

7. Optical Specifications

Item	Symbol	Condition	Min.	Typ.	Max.	Unit	Note
Brightness	-	-	-	80	-	cd/m ²	1
Viewing Angle	Hor.	Θx+	-	45	-	deg.	2
		Θx-	-	45	-		
	Ver.	Θy+	-	15	-		
		Θy-	-	35	-		
Contrast Ratio	Cr	Θx=Θy=0	150	250	-	-	3
Response Time	Tr	Θx=Θy=0	-	15	30	ms	4
	Tf		-	35	50	ms	
Chromaticity	White	x	0.282	0.312	0.342	-	-
		y	0.319	0.349	0.379	-	

Note 1: Measured at the center area of the panel when the LCD on the "White" state.

Note 2: The above "Viewing Angle" is the measuring position with largest contrast ratio, not for good image quality. Viewing direction for good image quality is 12 O'clock.

Normal

자세한 내용은 (주)가나시이스,
TEL: 02-2681-5611로 주시기 바랍니다.

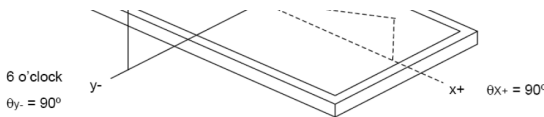

Note 3: The contrast ratio is defined as the following expression.

$$\text{Contrast Ratio (Cr)} = \frac{\text{Brightness measured when LCD on "White" State}}{\text{Brightness measured when LCD on "Black" state}}$$

Note 4: The response time is defined as the LCD optical switching time interval between "White" state and "Black" state. Rise time Tr is the time between photo detector output intensity changed from 90% to 10%. Fall time Tf is the time between photo detector output intensity changed from 10% to 90%.

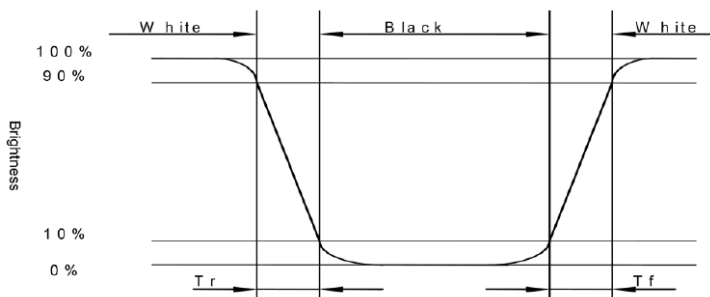

8. Outline Dimensions

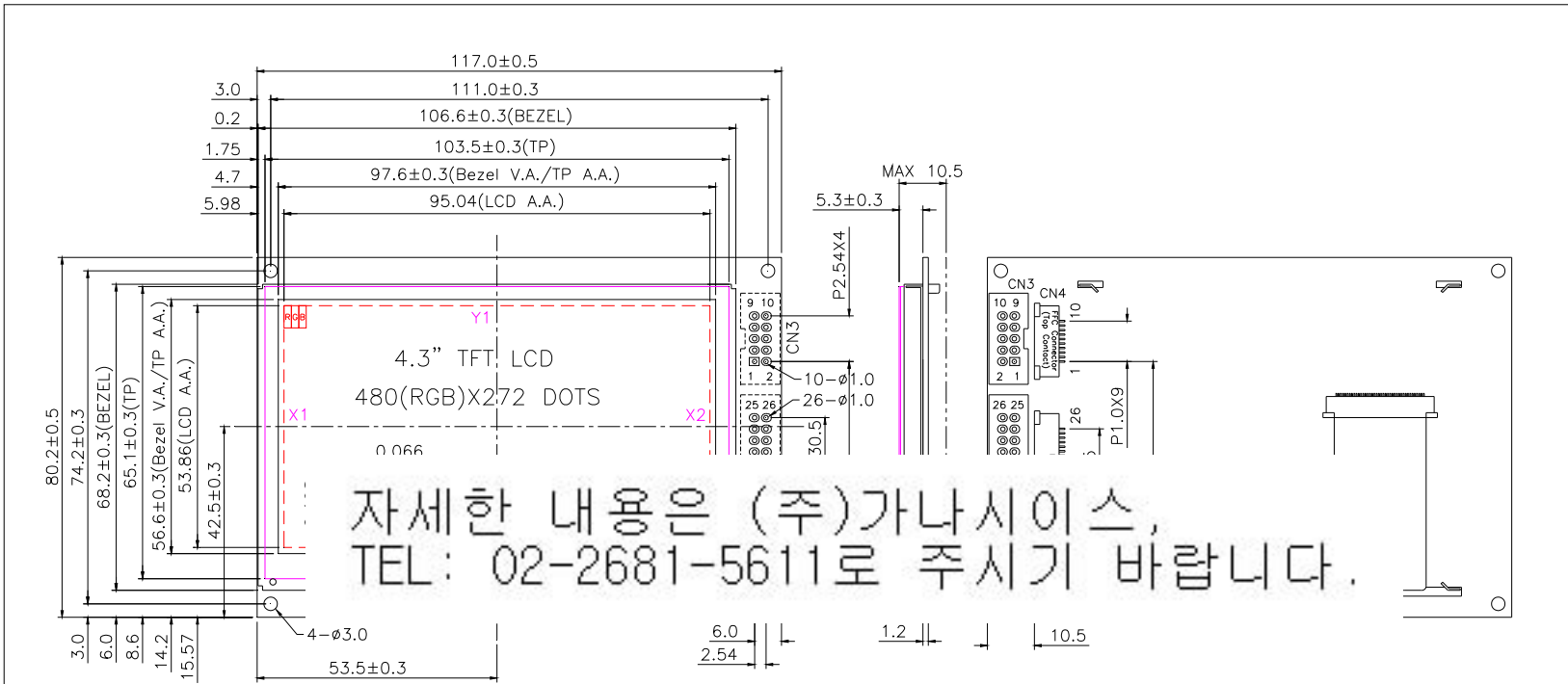

PIN ASSIGNMENT

PIN NO.	1	2	3	4	5	6	7	8	9	10
CN3,CN4	Vss	Vdd	VLED	SCL	SDI	SDO	/SCS	/WAIT	/INT	/RST

PIN NO.	1	2	3	4	5	6	7	8	9	10	11	12	13	14	15	16	17	18	19	20	21	22	23	24	25	26
CN1,CN2	Vss	Vdd	VLED	RS	/WR	/RD	/CS	/RST	/WAIT	/INT	DB0	DB1	DB2	DB3	DB4	DB5	DB6	DB7	DB8	DB9	DB10	DB11	DB12	DB13	DB14	DB15

- Notes:
- 4.3" Transmissive, Normally-White TFT-LCD Module
 - Viewing Direction: 6:00
 - LCD Controller: RA8875
 - Built-in LED Driver IC
 - Touch Panel: 4-Wire Analog
 - Operation Temp.: -20°C to +70°C
 - Storage Temp.: -30°C to +80°C

DWN.	LY	TITLE	LCM OUTLINE DIMENSION		
CHK.	LYJ	PART NO.	LT043C-T		
APPD.		DWG. NO.	LT043C-T-WXA		
REV.	A	UNIT	mm	PROJECTION	
DATE	2012.08.16	SCALE	NTS	SHEET	1 OF 1

9. Precautions for Use of LCD Module

9.1 Handling Precautions

- 1) The display panel is made of glass. Do not subject it to a mechanical shock by dropping it from a high place, etc.
- 2) If the display panel is damaged and the liquid crystal substance inside it leaks out, be sure not to get any in your mouth. If the substance comes into contact with your skin or clothes, promptly wash it off using soap and water.
- 3) Do not apply excessive force on the surface of display or the adjoining areas of LCD module since this may cause the color tone to vary.
- 4) The polarizer covering the display surface of the LCD module is soft and easily scratched. Handle this polarizer carefully.
- 5) If the display surface of LCD module becomes contaminated, blow on the surface and gently wipe it with a soft dry cloth. If it is heavily contaminated, moisten cloth with one of the following solvents.
 - Isopropyl alcohol
 - Ethyl alcohol Solvents other than those mentioned above may damage the polarizer.

Especially, do not use the following:

- Water

· ...

- 6) 자세한 내용은 (주)가나시이스,
TEL: 02-2681-5611로 주시기 바랍니다. n.
Dis e

outer case.

- 7) Be sure to avoid any solvent such as flux for soldering never stick to Heat-Seal. Such solvent on Heat-Seal may cause connection problem of heat-Seal and TAB.
- 8) Do not forcibly pull or bend the TAB I/O terminals.
- 9) Do not attempt to disassemble or process the LCD module.
- 10) NC terminal should be open. Do not connect anything.
- 11) If the logic circuit power is off, do not apply the input signals.
- 12) To prevent destruction of the elements by static electricity, be careful to maintain an optimum work environment.
 - Be sure to ground the body when handling the LCD module.
 - Tools required for assembly, such as soldering irons, must be properly grounded.
 - To reduce the amount of static electricity generated, do not conduct assembly and other work under dry conditions.
 - The LCD module is coated with a film to protect the display surface. Exercise care when peeling off this protective film since static electricity may be generated.

9.2 Storage Precautions

- 1) When storing the LCD module, avoid exposure to direct sunlight or to the light of fluorescent lamps and high temperature/high humidity. Whenever possible, the LCD module should be stored in the same conditions in which they were shipped from our company.
- 2) Exercise care to minimize corrosion of the electrodes. Corrosion of the electrodes is accelerated by water droplets or a current flow in a high humidity environment.

9.3 Design Precautions

- 1) The absolute maximum ratings represent the rated value beyond which LCD module can not exceed. When the LCD modules are used in excess of this rated value, their operating characteristics may be adversely affected.
- 2) To prevent the occurrence of erroneous operation caused by noise, attention must be paid to satisfy VIL, VIH specification values, including taking the precaution of using signal cables that are short.
- 3) The liquid crystal display exhibits temperature dependency characteristics. Since recognition of the display becomes difficult when the LCD is used outside its designated operating temperature range, be sure to use the LCD within this range. Also, keep in mind that the LCD driving voltage levels necessary for clear displays will vary according to temperature.
- 4) Sufficiently notice the mutual noise interference occurred by peripheral devices.

5)

6) 자세한 내용은 (주)가나시이스, ☎
by TEL: 02-2681-5611로 주시기 바랍니다. :he
op nt

to the LCD Module.

9.4 Others

- 1) Liquid crystals solidify under low temperatures (below the storage temperature range) leading to defective orientation or the generation of air bubbles (black or white). Air bubbles may also be generated if the LCD module is subjected to a strong shock at a low temperature.
- 2) If the LCD modules have been operating for a long time showing the same display patterns, the display patterns may remain on the screen as ghost images and a slight contrast irregularity may also appear. A normal operating status can be regained by suspending use for some time. It should be noted that this phenomenon does not adversely affect performance reliability.
- 3) To minimize the performance degradation of the LCD modules resulting from destruction caused by static electricity, etc., exercise care to avoid touching the following sections when handling the module:
 - Terminal electrode sections.
 - Part of pattern wiring on TAB.